

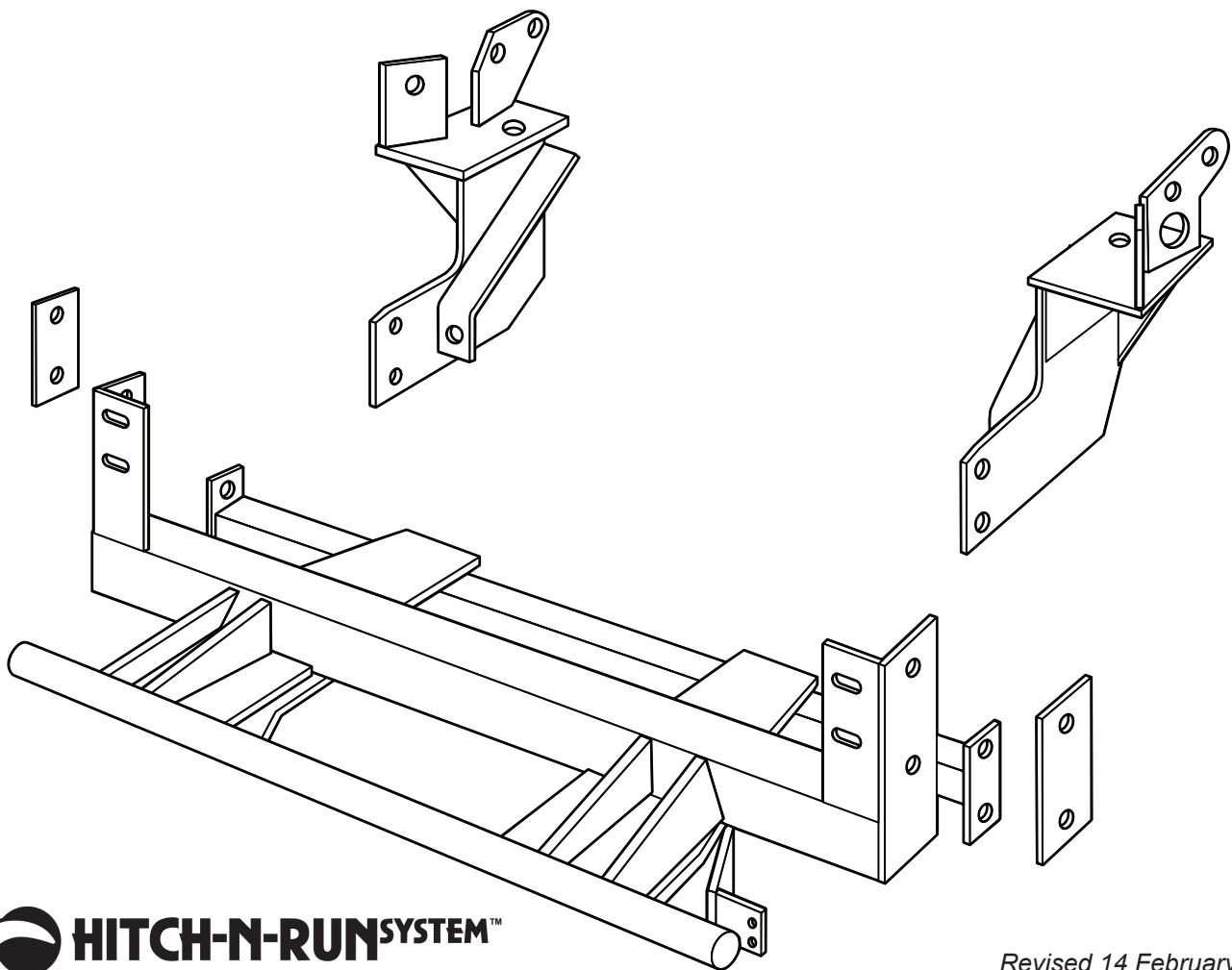

SNO-PRO[®] 3000

**1991 - 1996 Ford F-150
(With Snow Plow Prep. Package ONLY)**

Vehicle Mounting Kit: 1FK9



Revised 14 February 2011

Curtis Industries Inc. LLC, 111 Higgins St., Worcester, MA 01606 TEL: (800) 343-7676 FAX: (508) 854-3377 For Parts and information visit us at www.Curtisindustries.net
Curtis Industries Inc. LLC, reserves the right to change product design or specifications without notice or liability.
Curtis Snow Plows are protected by the following U.S. Patent Numbers: 6,145,222 and 6,209,231 Licensed under U.S. Patent Number 5,568,694 & Canadian Patent Number 2,137,853.
Other patents pending.

1FK9 Vehicle Mount Kit Parts List

Item #	Description	Qty.
1	Clamp Bar	2
2	Mounting Frame	1
3	Driver's Side Push Arm	1
4	Passenger's Side Push Arm	1
7	1/2"-13 x 1-1/2" Strap Bolt (21" Long)	4
13	3/4"-10 x 1-1/2" Special Toggle Bolt	2
Hardware Bag Components Included In This Kit		
5	1/2"-13 x 1-1/2" Bolt, Gr. 5, Cad., Plated	8
6	1/2"-13 x 4-1/2" Bolt, Gr. 5, Cad., Plated	4
8	1/2" Lockwasher, Cad., Plated	12
9	1/2"-13 Hex Nut, Cad., Plated	16
10	5/8"-11 x 2-1/2" Carriage Bolt, Gr. 5, Cad., Plated	2
11	5/8" Lockwasher, Cad., Plated	2
12	5/8"-11 Hex Jam Nut, Cad., Plated	4
14	3/4" Lockwasher, Cad., Plated	2
15	3/4"-10 Hex Nut, Cad., Plated	2
Hardware Components Included In Plow Kit		
2a	Plug Mount Bracket	1
-	10-32 x 3/4" Hex Head Screw, Plated	2
-	10-32 Nylock Lock Nut, Plated	2
-	8-32 x 1" Hex Head Screw, Plated	1
-	8-32 Nylock Lock Nut, Plated	1
-	#8 Nylon Flat Washer, 3/4" O.D.	1
-	#8 Flat Washer, SAE, Plated	1



WARNING

It is highly recommended that front "helper springs", "airshocks", or other similar devices be installed onto this vehicle to prevent the front suspension from "bottoming out" while carrying a snow plow.

Vehicle must be properly "ballasted" by placing ballast weight behind the centerline of Rear Axle so that no more than 62% of the total weight of the Vehicle, Snow Plow, Driver, Ballast weight, (and any cargo) is placed on the Front Axle while at the same time not exceeding the Gross Vehicle Weight Rating and Front or Rear Gross Axle Weight Ratings.

1FK9 Mounting

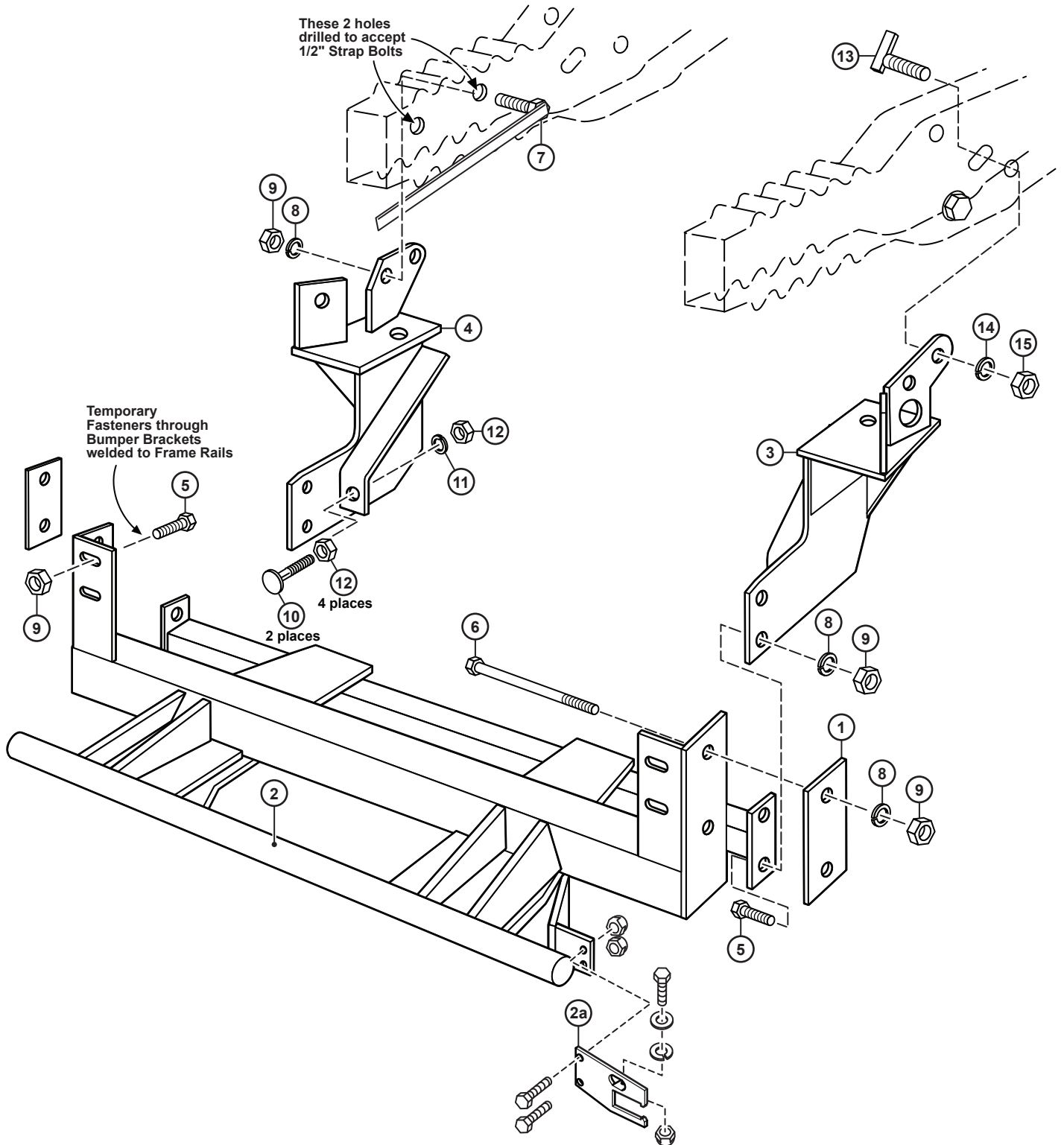

Curtis Industries, LLC. reserves the right to change product design or specifications without notice or liability. Curtis Snow Plows and Truck equipment should only be used on vehicles equipped with the manufacturer's Snow Plow preparation package. Snow Plowing without the original snow plow preparation package may damage your vehicle and the added weight of the equipment may impair the operation and control of the vehicle.

1FK9: 1991 - 1996 Ford F-150

Mounting Kit Installation Instructions

1. VEHICLE PREPARATION

- (1a.) Temporarily remove the vehicle front bumper by unbolting the bumper brackets from the frame rail brackets. Save all bumper fasteners for reuse.
- (1b.) Either remove the vehicle air dam completely or cut a 35" long section out of the center of it.
- (1c.) Screw a 5/8"-11 hex jam nut (12) all the way onto each of the 5/8"-11 x 2-1/2" carriage bolts (10). Place each carriage bolt / jam nut assembly through the ears on the driver's side and passenger's side push arms (3) & (4) with the heads of the carriage bolts toward the front of the vehicle. Fasten loosely using a 5/8" lockwasher (11) and 5/8"-11 hex jam nut (12) on each carriage bolt / jam nut assembly.



NOTE

All fasteners should remain loose or "finger tight" until all components have been attached to vehicle or installation instructions specify tightening.

2. MOUNTING FRAME

- (2a.) Lift the Mounting frame (2) up under the front of the vehicle with the front cross tube angle brackets between the frame rails and behind the vehicle bumper brackets (welded to the frame rails). Place 1/2"-13 x 4-1/2" bolts (6) out through the holes in the outer flange of the cross tube angle brackets. (One 1/2"-13 x 4-1/2" bolt (6) should be over the top flange and one should be under the bottom flange of the frame rail on each side.) Install a clamp bar (1) on over the ends of the 1/2"-1 x 4-1/2" bolts (6) on the outside of each frame rail. Fasten using 1/2" lock washers (8) and 1/2"-13 hex nuts (9).
- (2b.) Temporarily attach the front flange of the front cross tube angle brackets to the vehicle bumper brackets at the slotted holes using two 1/2"-13 x 1-1/2" bolts (5), and 1/2"-13 hex nuts (9) on each side. (These fasteners will be removed when the bumper is reinstalled in a later step in the installation.)

3. DRIVER'S SIDE PUSH ARM

- (3a.) Insert the head of a 3/4"-10 x 2" special toggle bolt (13) into the large slotted hole near the rear steering box bolt. Rotate the head of the toggle bolt so that the toggle "locks" into the slotted hole and will not turn. Place the rear most hole in the frame plate end of the driver's side push arm (3) on over the end of the toggle bolt (13) installed in the frame rail. Fasten using a 3/4" lockwasher (14) and 3/4"-10 hex nut (15).
- (3b.) Line up the two holes in the front end of the driver's side push arm (3) with the holes in the end plate of the rear cross tube of the mounting frame (2). Fasten using 1/2"-13 x 1-1/2" bolts (5), 1/2" lockwashers (8), and 1/2"-13 nuts (9). Two 1/2" dia. holes will have to be drilled in the outside flange of the frame rail at a later step in the installation.

4. PASSENGER'S SIDE PUSH ARM

Install the passenger's side push arm (4) in the same sequence and with the same amount and type of fasteners as the driver's side push arm (3).

5. DRILLING & TIGHTENING

- (5a.) Tighten the 1/2" fasteners holding the side flanges of the front cross tube angle brackets (on the mounting frame) and clamp bars (1) to the frame rails. Tighten the 1/2" fasteners holding the front flange of the front cross tube

angle brackets to the vehicle bumper brackets (welded to the frame rails).

- (5b.) Hold the driver's side and passenger's side push arms (3) & (4) up tight against the bottom flange of the frame rails and tighten the nuts on the 3/4"-10 x 2" special toggle bolts (13) installed in the frame rails and upper rear frame plates of the push arms. Tighten the 1/2" fasteners holding the front ends of the push arms (3) & (4) to the end plates of the rear cross tube on the mounting frame (2).
- (5c.) Using the front hole in each rear frame plate and the hole in the front frame plates on the push arms (3) & (4) as guides drill two 1/2" dia. holes through each frame rail. From inside each frame rail, insert two 1/2"-13 x 1-1/2" strap bolts (7) out through the 1/2" drilled holes and the frame plates of each push arm. Fasten and tighten using 1/2" lock washers (8), and 1/2"-13 nuts (9).
- (5d.) Adjust the 5/8"-11 x 2-1/2" carriage bolts (10) with the front 5/8" jam nuts (12) so that the heads of the carriage bolts are tight against the back of the rear cross tube of the mounting frame (2). Lock the 5/8"-11 x 2-1/2" carriage bolts (10) in place using the rear 5/8"-11 jam nuts (12). Remove and discard the four 1/2"-13 x 1-1/2" bolts (5) and nuts (9) holding the front flange of the front cross tube angle brackets on the mounting frame (2) to the vehicle bumper brackets.
- (5e.) Reinstall the front bumper using the original equipment fasteners through the vehicle bumper brackets and the front flange of the angle brackets with the nuts on the back side.

6. FINAL ADJUSTMENT AND INSPECTION

- (6a.) Align the front bumper with the vehicle grill and front body work, then tighten the original equipment bumper bracket nuts.
- (6b.) Inspect the mounting attachment bolts to be certain that they are all in place and that they are all tight.

7. OPTIONAL PLUG MOUNT BRACKET INSTALL



NOTE

Install the Plug Mount Bracket if the harness will be mounted on the frame kit, otherwise, the harness may be routed through the grill, bumper, etc.

Using (2) 10-32 x 3/4" hex bolts and nylon locknuts, fasten the Plug Mount Bracket to the Plug Mount Bracket Mounting Tab located on the driver's side of the frame kit receiver. The included 8-32 hardware is used for mounting the hi-amp battery leads to the Plug Mount Bracket if used.

